

# SXR - STROOPS XTREME ROWER

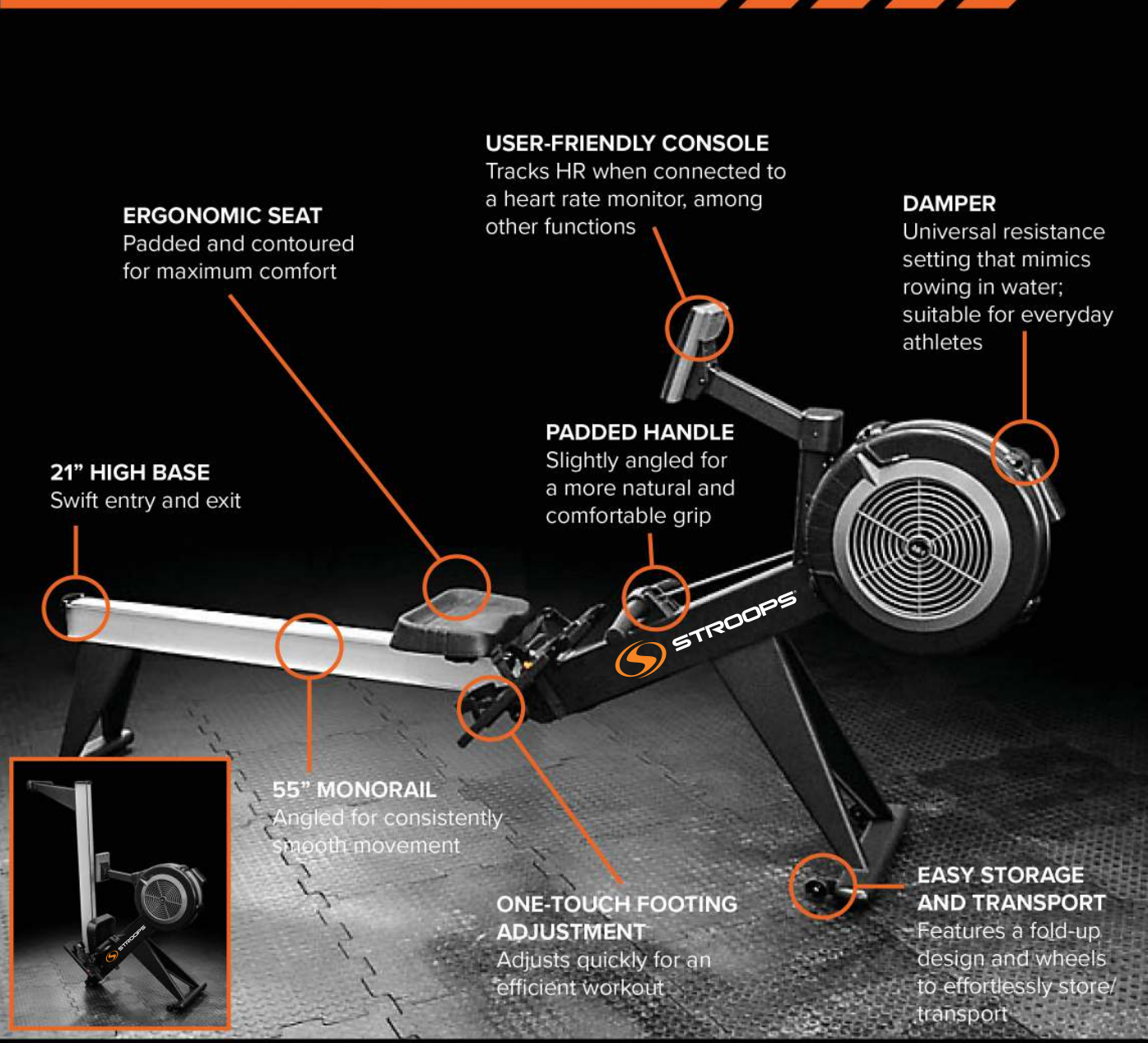

**ERGONOMIC SEAT**  
Padded and contoured for maximum comfort

**USER-FRIENDLY CONSOLE**  
Tracks HR when connected to a heart rate monitor, among other functions

**DAMPER**  
Universal resistance setting that mimics rowing in water; suitable for everyday athletes

**21" HIGH BASE**  
Swift entry and exit

**PADDED HANDLE**  
Slightly angled for a more natural and comfortable grip

**55" MONORAIL**  
Angled for consistently smooth movement

**ONE-TOUCH FOOTING ADJUSTMENT**  
Adjusts quickly for an efficient workout

**EASY STORAGE AND TRANSPORT**  
Features a fold-up design and wheels to effortlessly store/transport

The Stroops Xtreme Rower is designed for smooth, powerful movements. As your rows build momentum, the pulls become smoother. The rower is built so that there is no need for a strong "startup" pull or awkward starting position. The Stroops rower is the perfect compliment to any exercise regimine.

## CONSOLE

- Tracks distance, speed, pace, calories burned, watts and heart rate.
- Programmable interval functions
- Set distance time tracking

## SPECIFICATIONS

- Net Weight: 91 lbs.
- Ship Weight: 110 lbs.
- Ship Dimensions: 59" x 15" x 26"
- Row Position: 100L x 25W x 47.75H
- Folded Position: 57L x 25W x 62H

## WARRANTY

- 5 year: frame/welds
- 2 year: moving part